



Australian Divisions of **General Practice**

Divisions Network Information Management Project Discussion Paper – Version 0.2

Executive summary

This discussion paper aims to provide background information, identify requirements and options for a divisions network information management system that could be adopted by the Divisions of General Practice Network.

The development and implementation of a divisions network information management system will assist divisions in meeting their national performance indicator reporting requirements under the National Quality and Performance System (NQPS). The proposed system will support the efficiency of practices, maximise appropriate data access and help deliver best practice, quality care.

ADGP will consult with the divisions network to develop the proposed system. As part of this consultation process, the divisions network will have an opportunity to shape and define the functional requirements of the proposed system to extract, aggregate and analyse de-identified patient data from general practice. The consultation process will determine how information could be managed, data flows and levels of access by different divisions network members in the proposed system.

ADGP will define and scope the proposed system based on the divisions network consultation outcomes. This will include the preparation of detailed specification documentation and implementation planning. This documentation will be forwarded to the Department of Health and Ageing for endorsement and consideration of further funding to progress activities for the implementation phase.

As a result of the consultation process, ADGP will be able to design business cases and provide resources to divisions helping explain information management concepts and the importance of data quality to their members. This will assist divisions in showing their general practitioners (GPs) that using the information management system will bring immediate benefits to GPs in their daily work.

Introduction

NQPS has been developed by the Australian Government to drive continuous improvement across the entire divisions network. The national performance indicators reflect the government expectations of the divisions network, centred on the government's priority areas to strengthen primary health care.

NQPS allows divisions to demonstrate the benefits of the network to its members. It establishes a process to encourage strong performance and promote best practice. NQPS sharpens the focus of the network to support improved outcomes for primary care, while allowing divisions to respond to local needs in their community.

The divisions network has long argued for better integration in the primary health care sector. This requires establishment of inter-sectoral (ie, within primary health care) and cross-jurisdictional (ie, state and commonwealth) partnerships. It is for this reason the implementation of the NQPS will be developed in a consistent and cost effective manner across the entire divisions network.

At the ADGP Forum in November 2005, Minister Bishop announced funding of up to \$7 million over four years to support the implementation of the information management strategy. Key components include:

- Regional Health Information Management Officers (RHIMOs) across Australia, to support implementation and change in divisions
- a secure national system for divisions, to support shared information and knowledge
- tools and resources to support secure collection and management of agreed practice and clinical information, to assist with national performance indicator reporting.

ADGP has started the initial consultation stage of the divisions network information management system development. In consultation with the divisions network, the planning study will define the functional requirements of the proposed system. This process will consider cost implications, ease of implementation, continued use, technical support and willingness to adopt by GPs and divisions.

What model best suits the divisions network needs?

A national approach to the collection, aggregation, analysis and distribution of primary health care data assists divisions in their national performance reporting, planning requirements and improvements in general practice quality including consistency across the network and efficiency of health services.

General practice, with a focus on better management of information, can promote improved clinical, patient and practice outcomes enhancing the doctor-patient relationship and support the efficiency of practices. GPs work smarter and not harder.

The proposed system could allow the effective and efficient flow of de-identified, aggregated data reports from practices to divisions and benchmarking reports back to practices from divisions. This de-identified data could then be aggregated up to both a state level (SBOs) and a national level (ADGP). The table below indicates a proposed flow of data.

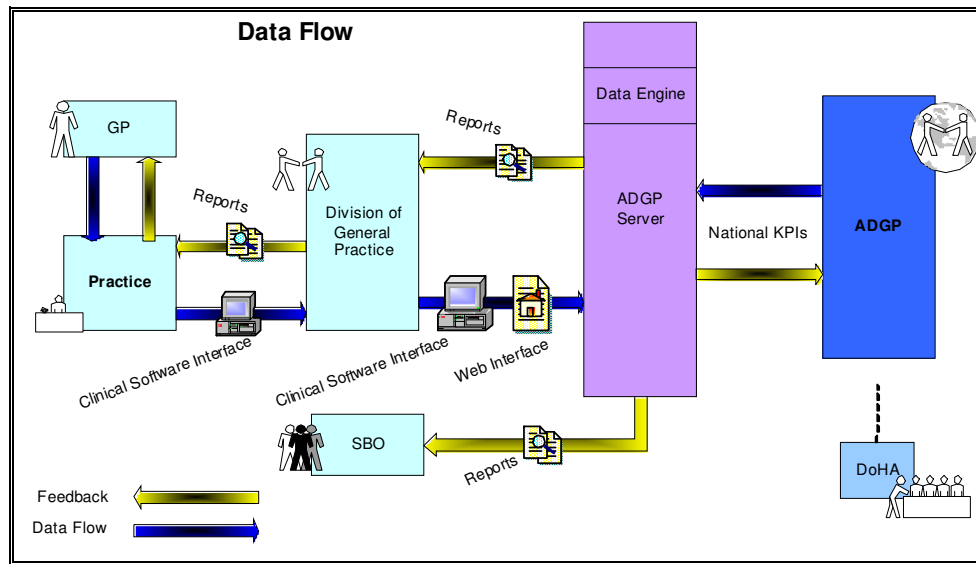

It is proposed that this system could capture all national performance indicators but there are particularly four indicators of importance. See Appendix A for detailed definitions. This system could also provide information to be used by divisions, SBOs and ADGP to initiate policy reforms, program delivery excellence and championing of models.

In designing this system, the divisions network has an opportunity to consider additional benefits that this system could provide for enhanced connectivity and communications across the network. It could be extended for example, to be a repository for population health statistics, a one-stop 'portal' to evidence based care, or have online surveying capacity.

The system must be capable of adapting to the continued growth and expansion of indicators and be capable of collecting other data sets such as the National Primary Care Collaboratives or indigenous data currently being designed and progressed.

What is the role of divisions?

Divisional consultation will be conducted over the next two months in two stages:

1. Broad consultation (Round 1), facilitated by RHIMOs and SBOs, including:
 - face-to-face meetings, workshops or teleconferences with a cross-section of Divisions of General Practice to define the draft functional requirements of the proposed system
2. Focused consultation (Round 2) including:
 - workshops with working groups to finalise the functional requirements of the proposed system
 - discussion at the ADGP-SBO Coalition meeting
 - ongoing activity of RHIMOs at divisional and state level

To view the consultation plan in detail, please visit the ADGP website.

Working groups will be established to ensure the expertise from the divisions network drives this study to investigate the implications for information management systems that need to be developed, sourced and/or enhanced to support the NQPS.

A steering committee has been set up to ensure the project aligns with the divisions network requirements. This committee has state and divisional representation. To view the steering committee's membership and terms of reference, please visit the ADGP website.

How to comment

Consultation and engagement with the divisions network has recently commenced and is due for completion by mid September 2006.

Please contact the SBO in your state/territory for further information.

Appendix A

DIABETES INDICATORS

Diabetes—Level 4 (Intermediate Outcomes)

N_DIA 4.1	
Indicator	Number and proportion of patients with diabetes on practice register/recall/reminder systems whose most recent HbA1c in the past 12 months was: <ul style="list-style-type: none">▪ 7.0% or less▪ more than 7% but less than 10.0%▪ 10.0% or more▪ not measured/not recorded.
N_DIA 4.2	
Indicator	Number and proportion of patients with diabetes on practice register/recall/reminder systems whose most recent total cholesterol in the past 12 months was: <ul style="list-style-type: none">▪ less than 4.0 mmol/L▪ 4.0 mmol/L or more▪ not measured.

ASTHMA INDICATORS

Asthma—Level 3 (Processes of Care)

N_ASM 3.1	
Indicator	Number and proportion of patients on practice register/recall/reminder systems with asthma aged 10 years and over with a record of smoking status.

Asthma—Level 4 (Intermediate Outcomes)

N_ASM 4.1	
Indicator	Number and proportion of patients on practice register/recall/reminder systems with asthma aged 10 years and over recorded as a current smoker.

MENTAL HEALTH INDICATORS

Mental Health—Level 4 (Intermediate Outcomes)

Please note that the N_MNH 4.1 indicator is still under development. Divisions are not required to report against this indicator. It is therefore outside the scope of the project at present.